

Integrating Sustainable Touchless Technology into Practical Learning for Educational Impact

N. Mazalan¹, N. H. M. Yusoff², J. Mohamad¹ and SY. Y. Yakub³

¹Kolej Komuniti Masjid Tanah,
78300 Paya Rumput, Melaka, Malaysia.

²Politeknik Merlimau Melaka
77300 Merlimau, Melaka, Malaysia.

³Universitas Multimedia Nusantara
Kec. Kelapa Dua, Kab. Tangerang,
15810, Prop. Banten, Indonesia

Corresponding Author's Email: nabilah@kkmt.edu.my

Article History: Received 12 January 2026; Revised 10 March 2026;

Accepted 30 Mei 2026;

©2026 N. Mazalan et al. Published by Jabatan Pendidikan Politeknik dan Kolej Komuniti.

This article is an open article under the CC-BY-NC-ND license

(<https://creativecommons.org/licenses/by-nc-nd/4.0/>).

Abstract

The integration of sustainability, hygiene awareness, and smart automation has created opportunities for practical learning in TVET education. This study presents the design and development of an IoT-based touchless tissue dispenser as a practical learning prototype. The system was developed using an ESP32 microcontroller, ultrasonic sensor, servo motor, OLED display, LED indicator, and the Blynk IoT platform. A design and development approach guided by the Waterfall Model was applied, covering requirements analysis, system design, implementation, integration, testing, and deployment planning. The prototype was also mapped to project-based learning activities involving circuit design, microcontroller programming, mobile dashboard configuration, system testing, troubleshooting, and sustainability reflection. Functional validation through Wokwi simulation and prototype testing showed that the system was able to dispense tissue automatically when hand proximity was detected within 15 cm, remain in standby mode when no hand was detected, display real-time distance and status information, and support manual activation through the Blynk mobile interface. The prototype demonstrates the potential of low-cost IoT-based automation to support hands-on learning in electronics, programming, sensor integration, and sustainable technology applications. It provides a practical example of how touchless technology can be integrated into TVET learning activities without relying solely on theoretical instruction.

Keywords: IoT Education, Project-Based Learning, Sustainable Technology, Touchless Automation, TVET Practical Learning

1.0 Introduction

The convergence of environmental sustainability, smart automation, and digital transformation has increasingly influenced the direction of technical and vocational education. As industries and educational institutions respond to the demands of Industry 4.0, practical learning activities are expected to expose learners not only to technical skills, but also to real-world problem solving, sustainable practices, and technology-enabled innovation. Sustainable education has been widely discussed as an important approach for preparing learners to address environmental and technological challenges in modern society (Mian et al., 2020; Vinçte et al., 2021). In technical education, the integration of automation, embedded systems, and Internet of

Things (IoT) applications provides opportunities for students to connect theoretical concepts with practical implementation, particularly in areas related to smart systems and green technology (Aköz et al., 2022; Zondo et al., 2020).

Touchless dispensing systems represent a relevant and practical context for integrating sustainability, hygiene awareness, and automation into educational projects. Conventional tissue dispensers are commonly used in public and private facilities, yet they often rely on manual operation and may contribute to excessive tissue consumption when not properly controlled. Manual contact with shared dispensers can also raise hygiene concerns, especially in high-traffic environments (Lichtner et al., 2021). Previous studies on intelligent and automated dispensing systems have shown that sensor-based technologies can improve user convenience, reduce unnecessary contact, and support more efficient operation (Man et al., 2019; Lesmana et al., 2020). Among the commonly used sensing technologies, ultrasonic sensors have been applied widely due to their ability to detect object proximity with reasonable accuracy, reliability, and energy efficiency (Juruš & Ferencík, 2021).

Recent developments in smart automation have further expanded the role of microcontroller-based systems in practical applications. Arduino-based systems have been used in various automated dispensing and monitoring projects because they are low-cost, accessible, and suitable for educational prototyping (Koh et al., 2024). Similarly, automated touchless systems such as sanitizer dispensers demonstrate how embedded platforms, sensors, and actuators can be combined to address hygiene-related problems through practical engineering solutions (Kumar Das et al., 2021). However, many of these systems operate mainly as standalone devices, where functionality is limited to local sensor detection and mechanical actuation. Although such systems are useful for demonstrating basic automation, they provide limited exposure to cloud-based monitoring, mobile interfaces, and remote-control functions that are increasingly relevant in smart home, healthcare, and IoT-enabled environments (Chi et al., 2025; Fang et al., 2022).

The use of ESP32 and cloud-connected platforms such as Blynk provides an opportunity to extend standalone automation systems into interactive IoT-based prototypes. ESP32 offers built-in Wi-Fi capability, making it suitable for real-time data communication and wireless control in embedded IoT applications (Hercog et al., 2023). Blynk has also been applied in IoT projects as a mobile-based platform that allows users to monitor sensor readings and control devices remotely through a smartphone interface (Putra et al., 2021). In educational settings, microcontroller programming and mobile-based control systems can support students in understanding automation logic, data transmission, interface configuration, and system integration (Márquez-Vera et al., 2023). Therefore, upgrading a conventional or standalone dispenser into an IoT-enabled system is not only a technical improvement, but also a meaningful way to expose learners to current practices in smart automation.

From a pedagogical perspective, practical IoT development aligns closely with project-based learning (PBL), where students learn through the process of designing, building, testing, and improving a functional prototype. PBL has been recognised as an effective approach for supporting active learning, problem solving, and technical skill development, particularly in technology-based subjects (Nurbekova et al., 2020). The development of IoT prototypes requires learners to engage with circuit design, sensor integration, microcontroller programming, mobile application configuration, troubleshooting, and functional testing. These activities are consistent with practical learning needs in TVET, where students are expected to develop both conceptual understanding and hands-on competency. Studies on technology-enhanced learning and didactic platforms also suggest that smart system development can strengthen the connection between classroom learning and real-world applications (Elloumi et al., 2020; Cui et al., 2022).

Although previous studies have demonstrated the usefulness of automated dispensers, smart monitoring systems, and IoT-based learning tools, the literature remains more strongly focused on technical functionality than on how such prototypes can be structured as practical learning activities. Existing works commonly describe system components, sensor operation, and device performance, but provide limited explanation of how the development process contributes to student learning, sustainability awareness, and TVET pedagogy. In addition, earlier dispenser-based projects often do not fully integrate IoT features such as mobile monitoring, remote manual activation, and real-time feedback. This indicates a gap between the availability of sustainable automation prototypes and their systematic use as educational tools for project-based practical learning.

This study addresses the gap by extending an earlier eco-friendly Arduino-based tissue dispenser developed by Mazalan et al. (2024) into an ESP32 and Blynk-enabled IoT prototype. The upgraded system integrates an ultrasonic sensor, servo motor, OLED display, LED indicator, ESP32 microcontroller, and Blynk mobile interface to support automatic dispensing, real-time distance monitoring, visual feedback, and remote manual control. Beyond the technical enhancement, the prototype is positioned as a practical learning platform that allows TVET learners to experience embedded system design, IoT configuration, mobile dashboard development, functional testing, and sustainability-oriented problem solving. This approach is consistent with broader efforts to integrate smart automation and sustainable technology into education, particularly in preparing learners for emerging roles in green technology and IoT-related fields (Vicente et al., 2020; Wanyama et al., 2023). Accordingly, this study focuses on the design, development, and educational integration of an IoT-based touchless tissue dispenser for practical learning. The work contributes a functional prototype that demonstrates automatic and remote-control operation, while also presenting a structured example of how sustainable touchless technology can be embedded into PBL activities for TVET learners. By combining sensor-based automation, mobile IoT interaction, and sustainability awareness, the study highlights the potential of simple embedded systems to support applied learning, technical competency, and responsible technology use in educational environments.

2.0 Methodology

This study employed a design and development research approach supported by PBL mapping. The Waterfall Model (Royce, 1987) guided the technical development of the IoT-based touchless tissue dispenser, while PBL mapping was used to organise the prototype development into potential practical learning activities. This approach ensures that the study explains both the technical development of the prototype and its relevance to practical learning. The educational context of this study is framed within TVET practical learning related to electronics, microcontroller programming, sensor integration, and IoT applications. Since the study focuses on prototype design and functional validation rather than empirical classroom evaluation, no student participants, sampling procedure, or learner assessment data are reported. Instead, the educational component is presented through a PBL mapping that illustrates how the development of the IoT-based touchless tissue dispenser can be organised as a structured practical activity. The proposed PBL sequence includes problem identification, circuit design, ESP32 programming, Blynk dashboard configuration, prototype integration, functional testing, troubleshooting, and sustainability reflection. This approach allows the prototype to be positioned as a practical learning tool for TVET settings without making unsupported claims about measured student learning outcomes. Figure 1 illustrates the five development phases used in the study: requirements analysis, system design, development and implementation, integration and testing, and deployment and maintenance. Each phase was mapped to technical outputs and potential educational learning activities.

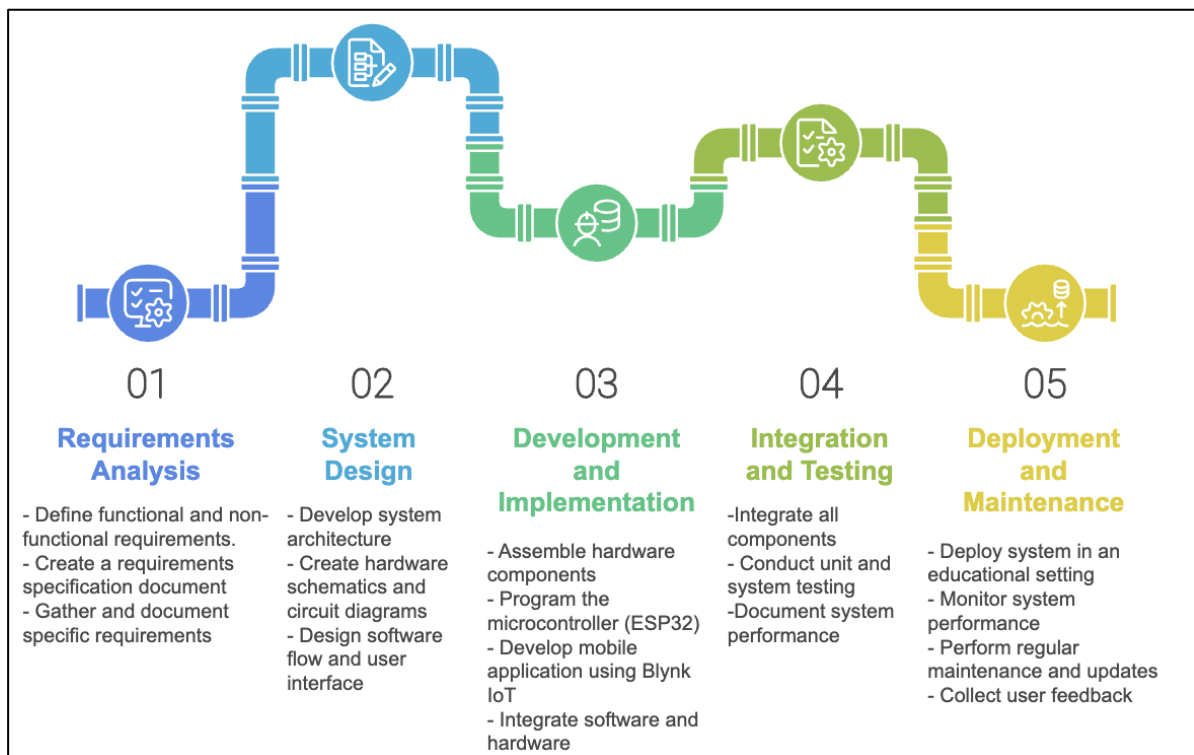

Figure 1: Waterfall Model

2.1 Requirements Analysis

The requirements analysis identified the functional, non-functional, and educational requirements for the IoT-based touchless tissue dispenser. Functional requirements focused on automatic tissue dispensing, manual remote triggering, real-time distance monitoring, and status display. Non-functional requirements addressed reliability, safety, response time, interface usability, and Wi-Fi connectivity. Educational requirements focused on demonstrating the relationship between sensor input, actuator output, IoT dashboard configuration, and sustainability considerations.

Table 1: Functional, Non-Functional and Educational Requirements

Category	Requirement Description
Functional	Detect hand proximity using ultrasonic sensor
	Automatically dispense tissue via servo motor
	Display system status and distance data on OLED
	Trigger LED during dispensing operation
	Allow manual dispensing through Blynk app (V1)
	Send real-time distance data to Blynk dashboard (V0)
Non-Functional	Ensure fast response time (<1s detection-dispense cycle)
	Maintain reliability and stability during continuous operation
	Provide intuitive and user-friendly mobile interface
	Support Wi-Fi connectivity with ESP32 and Blynk
	Ensure safe operation for classroom or public deployment
Educational	Demonstrate circuit design, programming, IoT configuration, testing, and sustainability reflection

2.2 System Design

The system design integrates hardware and software components to support automatic dispensing, real-time feedback, and mobile-based monitoring. The ESP32 functions as the central processing unit, linking the ultrasonic sensor, servo motor, OLED display, LED indicator, and Blynk IoT platform within a single control architecture. The ultrasonic sensor detects hand proximity, the servo motor executes the dispensing movement, the OLED display provides local distance and status feedback, and the LED indicator signals active dispensing. The Blynk IoT platform extends the system with wireless monitoring and manual control through a smartphone dashboard. Table 2 summarises the major components and development tools used to implement the proposed IoT-based touchless tissue dispenser.

Table 2: Major Components and Development Tools Used in the System

Component/Tool	Description
ESP32	Microcontroller for processing sensor input and managing wireless control
Ultrasonic Sensor (HC-SR04)	Measures hand distance for automatic triggering
Servo Motor (SG90)	Controls mechanical arm to push tissue
OLED Display (SSD1306)	Displays distance, status, and feedback messages
LED	Visual indicator during dispensing operation
Jumper Wires & Breadboard	For prototyping and establishing connections
Blynk IoT Platform	Enables wireless monitoring and manual control via smartphone
Arduino IDE	Software used for coding and uploading to ESP32
Wi-Fi Network (Wokwi Virtual)	Enables real-time IoT communication and cloud data transfer

Figure 2 illustrates the complete hardware architecture of the IoT-based touchless tissue dispenser implemented in Wokwi. The ESP32 acts as the central controller, integrating the ultrasonic sensor for proximity detection, the servo motor for dispensing actuation, the LED for operation indication, and the OLED display for real-time feedback. The wiring structure shows the separation of sensing, actuation, and feedback functions, enabling clear signal flow from hand detection to automated dispensing and status display.

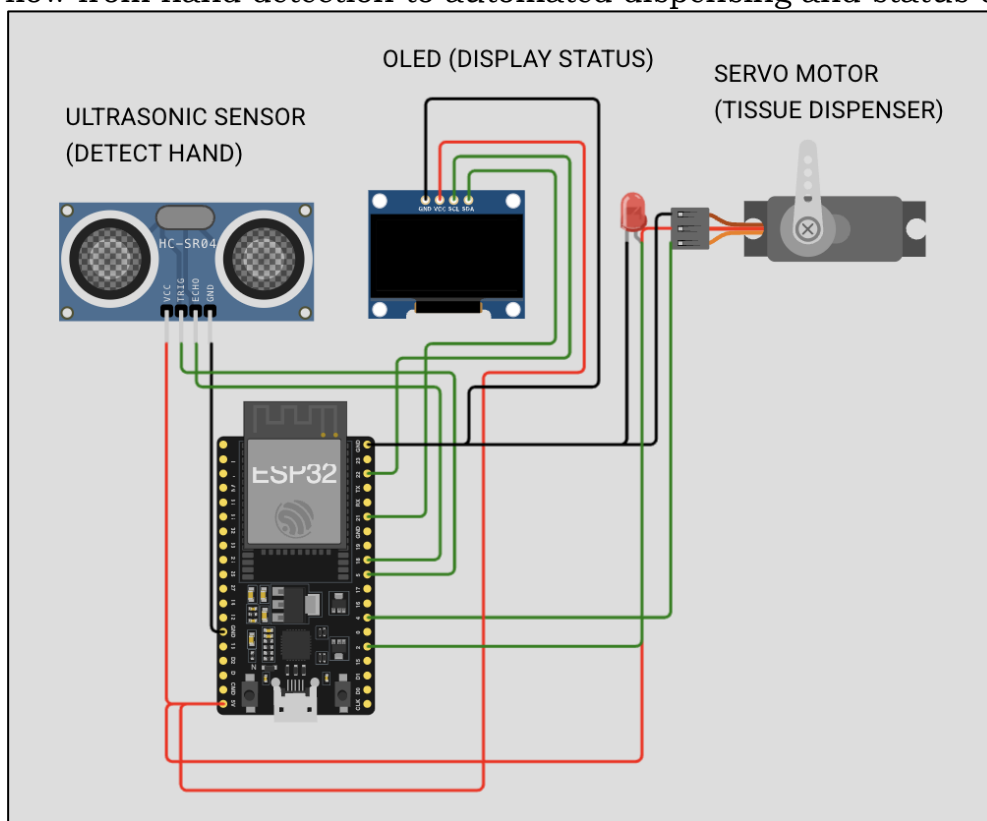

Figure 2 : System Wiring Diagram of the IoT-Based Tissue Dispenser

Table 3 : Pin Connections Between ESP32 and Components

Component	ESP32 Pin	Function
Ultrasonic Sensor	Trig – GPIO 5	Sends ultrasonic pulse
	Echo – GPIO 18	Receives pulse for distance
Servo Motor	Signal – GPIO 4	Controls tissue dispenser movement
LED	GPIO 2	Activates during dispensing
OLED Display (I2C)	SDA – GPIO 21	I2C Data Line
	SCL – GPIO 22	I2C Clock Line

Table 3 presents the ESP32 pin assignment used for system integration. The ultrasonic sensor is connected to GPIO 5 and GPIO 18 for trigger and echo signals, while the servo motor is assigned to GPIO 4 to control the dispensing mechanism. The LED indicator is connected to GPIO 2, and the OLED display uses the I2C interface through GPIO 21 and GPIO 22. This pin configuration ensures stable component communication, simplifies troubleshooting, and supports reliable prototype replication for practical learning activities.

2.3 Development and Implementation

The development phase involved physical integration of hardware components and the development of software logic. The ESP32 was connected to the ultrasonic sensor, servo motor, OLED display, and LED indicator on a breadboard to allow flexible adjustment during testing. The physical setup is shown in Figure 3.

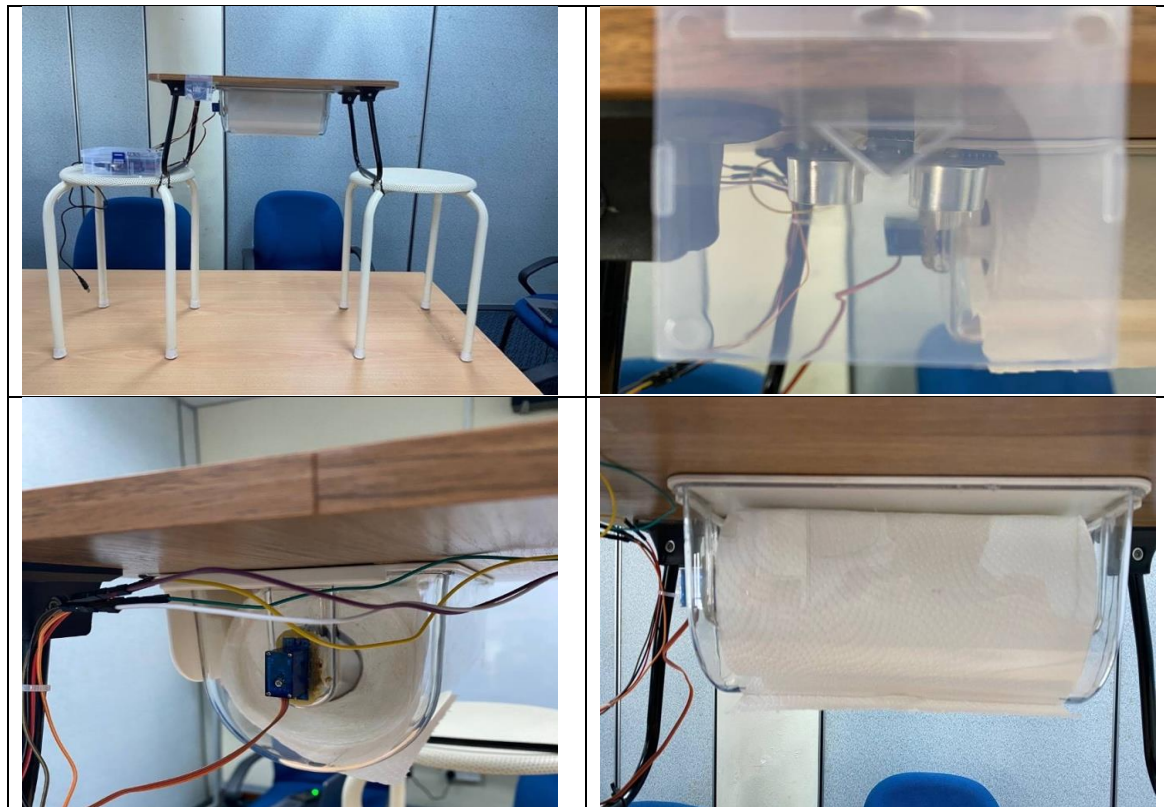

Figure 3 : Hardware Implementation

The firmware was developed using the Arduino IDE. The program reads distance data from the ultrasonic sensor, sends the data to Blynk, updates the OLED display, and activates the servo motor and LED when the hand distance is below the 15 cm threshold. Figure 4 shows the core code segment used for sensor reading and actuator control.

```
void readSensor() {
  if (manualMode) return; // Skip auto detection when manual mode is active

  digitalWrite(TRIG_PIN, LOW);
  delayMicroseconds(2);
  digitalWrite(TRIG_PIN, HIGH);
  delayMicroseconds(10);
  digitalWrite(TRIG_PIN, LOW);

  duration = pulseIn(ECHO_PIN, HIGH);
  distance = duration * 0.034 / 2;

  Serial.print("Distance: ");
  Serial.println(distance);
  Blynk.virtualWrite(V0, distance);

  display.clearDisplay();
  display.setCursor(0, 0);
  display.println("Tissue Dispenser");
  display.print("Distance: ");
  display.print(distance);
  display.println(" cm");

  if (distance < 15) {
    display.println("Status: Dispensing");
    display.display();
    digitalWrite(LED_PIN, HIGH);
    myServo.write(90);
    delay(1000);
    myServo.write(0);
    digitalWrite(LED_PIN, LOW);
  }
}
```

Figure 4 : Sample Arduino Code Snippet

The Blynk dashboard was configured to display real-time distance values and provide a manual trigger for dispensing. This allows the prototype to demonstrate the comparison between automatic sensor-based control and remote mobile-based control. The mobile interface is shown in Figure 5.

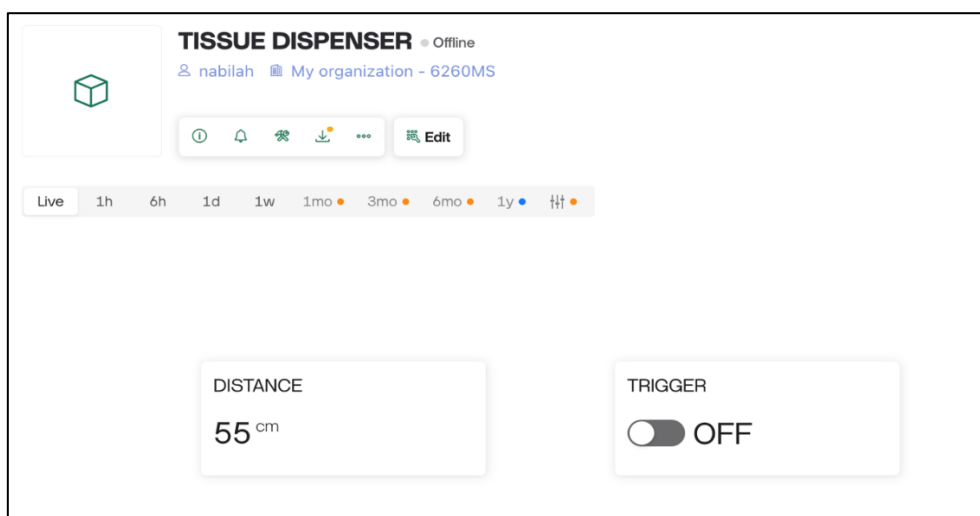

Figure 5: Mobile Interface Developed in Blynk for Real-Time Control and Monitoring

2.4 Integration and Testing

The integration and testing phase was conducted to verify the interaction between hardware, firmware, and the Blynk IoT platform. The ESP32, ultrasonic sensor, servo motor, OLED display, LED indicator, and Blynk dashboard were integrated based on the wiring and pin configuration defined in the system design phase. Testing was carried out in two stages: unit testing and system integration testing.

Unit testing was performed to confirm the operation of each component before full system integration. The ultrasonic sensor was tested for hand proximity detection, the servo motor was calibrated for dispensing movement, the LED indicator was verified for activation status, and the OLED display was checked for real-time distance and system feedback. Figure 6 shows the OLED output during testing, where the display presents the measured distance and current system status. This confirms that the ESP32 successfully processed the ultrasonic sensor input and displayed the corresponding feedback locally.

After the individual components were verified, system integration testing was performed to evaluate the complete operation flow. The testing focused on automatic dispensing when a hand was detected within the threshold distance, standby operation when no hand was detected, OLED status display, LED indication, Blynk distance monitoring, and manual activation through the mobile interface. The functional testing outcomes are presented and discussed in the Results and Discussion section.

2.5 Deployment and Maintenance

After successful integration and testing, the system can be deployed in an educational laboratory or classroom demonstration setting. Deployment involves positioning the ultrasonic sensor to detect hand proximity, ensuring the servo motor is aligned with the tissue holder, and connecting the ESP32 to a stable Wi-Fi network for Blynk operation. Maintenance includes checking wiring connections, verifying servo responsiveness, ensuring that the ultrasonic sensor is unobstructed, updating firmware when the detection threshold is changed, and confirming that the Blynk dashboard remains functional. These maintenance activities can also be used to demonstrate how system reliability depends on both hardware and software conditions.

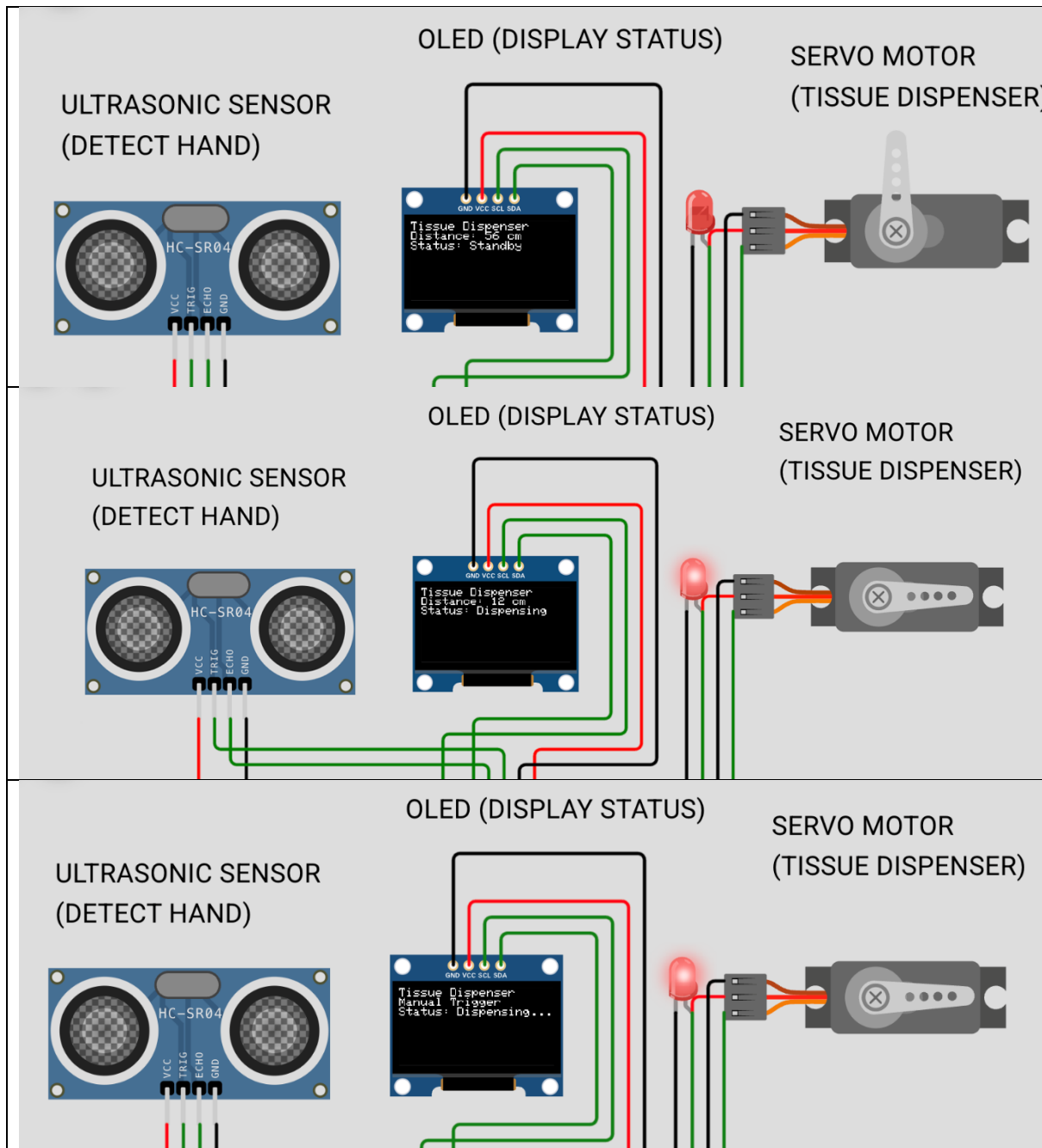

Figure 6: OLED Display Showing Distance and Status

3.0 Results and Discussion

3.1 Functional Validation of the Prototype

The IoT-based touchless tissue dispenser was successfully developed and validated through Wokwi simulation and prototype testing. The system operates in two modes: automatic mode and manual mode. In automatic mode, hand proximity detected within 15 cm triggers the ESP32 to activate the servo motor, switch on the LED indicator, update the OLED display, and dispense tissue. In manual mode, the dispenser can be remotely activated through the Blynk mobile dashboard, while real-time distance data are continuously displayed through the assigned virtual pin.

Table 4 presents the functional testing scenarios and results of the developed prototype. The tests were conducted to verify proximity detection, dispensing response, standby operation, mobile-based manual control, real-time distance monitoring, and OLED feedback.

Table 4 : Functional Testing Scenarios and Results

Test Scenario	Expected Output	Result	Status
Hand detected < 15 cm	Servo rotates and LED blinks	Success	Pass
Hand detected > 15 cm	System remains in standby	Success	Pass
Blynk manual trigger ON	Continuous dispensing (servo at 90°)	Success	Pass
Blynk manual trigger OFF	Stop dispensing, standby display	Success	Pass
Distance updates on Blynk (V0)	Real-time distance in cm	Accurate	Pass
OLED display shows status & distance	Live feedback displayed	Success	Pass

The results show that all tested functions operated according to the expected system behaviour. The proximity threshold responded consistently during simulation and prototype testing, while the Blynk dashboard successfully extended the system from local automation to mobile-based interaction. The OLED display and Blynk interface also provided real-time feedback from the same sensor input, demonstrating effective integration between local display output and cloud-connected monitoring. These findings confirm that the prototype achieved its intended functional requirements and is suitable for demonstrating IoT-based automation in TVET practical learning.

3.2 Educational Relevance and Pedagogical Discussion

The educational contribution of the prototype is reflected in its potential use as a practical learning tool for TVET-based IoT education. The development process involves several technical tasks that are relevant to project-based learning, including problem identification, circuit design, ESP32 programming, sensor-actuator integration, Blynk dashboard configuration, system testing, and troubleshooting. These tasks allow the prototype to be positioned not only as a functional dispenser, but also as a structured platform for demonstrating embedded system operation, mobile-based monitoring, and sustainable automation. Since this study focuses on design, development, and functional validation, no empirical classroom data or student learning assessment is reported. Therefore, the pedagogical discussion is limited to the relevance of the prototype for supporting hands-on learning activities. The system provides a practical context for connecting programming logic with physical system behaviour, particularly through the 15 cm detection threshold, servo motor activation, OLED feedback, and Blynk-based remote control. This makes the prototype suitable for introducing learners to the relationship between sensors, actuators, microcontrollers, cloud monitoring, and sustainability-oriented problem solving.

3.3 Comparison with Previous Studies and Study Limitations

Compared with the earlier Arduino-based tissue dispenser developed by Mazalan et al. (2024), the upgraded prototype adds ESP32-based wireless connectivity, real-time mobile monitoring, OLED feedback, and manual remote activation through Blynk. These enhancements extend the system from standalone automation to an IoT-enabled learning prototype. The integration of mobile monitoring and remote control also reflects current trends in smart home, healthcare, and IoT-based applications (Chi et al., 2025; Fang et al., 2022). The study also supports previous discussions that practical technology projects can strengthen applied learning when learners are exposed to the process of designing, testing, and improving a working artefact (Nurbekova et al., 2020). Similar to other sustainability-oriented STEM projects, the prototype provides a concrete context for discussing hygiene, resource control, and responsible technology use (Aköz et al., 2022; Vicente et al., 2020). However, the current study is limited to prototype development and functional validation. Future research should include classroom implementation, participant data, validated instruments, student feedback, and pre-test and post-test results to provide stronger evidence of learning effectiveness.

4.0 Conclusion

This study presented the design and development of an IoT-based touchless tissue dispenser using ESP32, an ultrasonic sensor, a servo motor, an OLED display, an LED indicator, and the Blynk IoT platform. The prototype was successfully developed to support automatic dispensing, manual remote activation, real-time distance monitoring, and local status feedback. Functional testing confirmed that the system operated according to the intended logic, particularly in detecting hand proximity within the 15 cm threshold, activating the dispensing mechanism, displaying system status, and transmitting data to the mobile dashboard.

The main contribution of this study is the integration of sustainable touchless automation with IoT-based practical learning. Compared with a standalone dispenser, the upgraded prototype provides wider learning value by demonstrating sensor-actuator interaction, microcontroller programming, mobile dashboard configuration, wireless monitoring, and system validation. The prototype also provides a practical context for introducing sustainability, hygiene awareness, and responsible technology use in TVET learning environments.

For future improvement, the system can be enhanced by adding a tissue-level monitoring sensor, data logging function, and a more robust enclosure for real deployment. Future studies should also include classroom implementation with proper educational data, such as participant information, validated instruments, student feedback, and pre-test and post-test results. These additions would strengthen the evidence on student engagement, learning effectiveness, and pedagogical impact.

Acknowledgement

The authors would like to extend their sincere gratitude to Kolej Komuniti Masjid Tanah and Jabatan Pendidikan Politeknik dan Kolej Komuniti for their support and contributions to this research endeavour.

Author Contributions

N. Mazalan: Conceptualisation, Abstract, Introduction and Discussion; **N. H. M. Yusoff:** Methodology, Hardware Integration and Testing, Results; **J. Mohamad:** Software, Validation, Writing-Reviewing and Editing; **SY. Y. Yakub:** Collaborator.

Conflicts of Interest

The manuscript has not been published elsewhere and is not under consideration by any other journal. All authors have reviewed and approved the manuscript, consent to its submission, and declare that there are no conflicts of interest.

References

- Aköz, O., Çeliker, H. D., & Genç, H. (2022). A course content designed in accordance with the 5E teaching model within the scope of STEM learning approach in environmental education course: My smart greenhouse. *European Journal of Education Studies*, 9(4). <https://doi.org/10.46827/ejes.v9i4.4263>
- Chi, H., Ma, Q., Wang, Y., Yang, J., & Geng, H. (2025). IoTBystander: A non-intrusive dual-channel-based smart home security monitoring framework. *Applied Sciences*, 15(9), 4795. <https://doi.org/10.3390/app15094795>
- Cui, X., Chen, J., & Ma, C. (2022). Teaching reform of theory and practice course of analog electronic technology under the new engineering background. *Journal of Education and Educational Research*, 1(2), 26. <https://doi.org/10.54097/jeer.v1i2.3050>
- Elloumi, K., Ayadi, N., Medhaffar, H., & Abid, D. B. H. (2020). Towards an integration of “SmartHome” technology in education: Realization of a didactic platform. *Proceedings of the International Multi-Conference on Systems, Signals & Devices (SSD)*. <https://doi.org/10.1109/ssd49366.2020.9364238>
- Fang, Z., Fu, H., Gu, T., Hu, P., Song, J., Jaeger, T., & Mohapatra, P. (2022). IOTA: A framework for analyzing system-level security of IoTs. *2022 IEEE/ACM International Conference on Internet of Things Design and Implementation (IoTDI)*. <https://doi.org/10.1109/iotdi54339.2022.00017>
- Hercog, D., Lerher, T., Truntič, M., & Težak, O. (2023). Design and implementation of ESP32-based IoT devices. *Sensors*, 23(15), 6739. <https://doi.org/10.3390/s23156739>
- Juruš, O., & Ferenčík, P. (2021). Ultrasonic sensors used to detect the position of the mobile service robot. *Acta Mechanica Slovaca*, 25(1), 28. <https://doi.org/10.21496/ams.2021.010>
- Koh, Y. Y., Kok, C. L., Ibraahim, N., & Guan, L. (2024). Smart water ATM with

- Arduino integration, RFID authentication, and dynamic dispensing for enhanced hydration practices. *Electronics*, 13(9), 1657. <https://doi.org/10.3390/electronics13091657>
- Kumar Das, A., Barua, A., Ajwad Mohimin, M., Jainal Abedin, M., Uddin Khandaker, M., & Almugren, K. S. (2021). Development of a novel design and subsequent fabrication of an automated touchless hand sanitizer dispenser to reduce the spread of contagious diseases. *Healthcare*, 9(4), 445. <https://doi.org/10.3390/healthcare9040445>
- Lesmana, J., Halim, A., & Purna Irawan, A. (2020). Design of automatic hand sanitizer with ultrasonic sensor. IOP Conference Series: *Materials Science and Engineering*, 1007(1), 012164. <https://doi.org/10.1088/1757-899X/1007/1/012164>
- Lichtner, V., Prgomet, M., Gates, P., Franklin, B. D., & Westbrook, J. (2021). Evaluation of an automated dispensing cabinet in paediatric intensive care – Focus on controlled medications. *Studies in Health Technology and Informatics*. <https://doi.org/10.3233/SHTI210733>
- Man, M., Azelee Wan Abu Bakar, W., & Irfan Hakim Mohd, M. (2019). ITDS: An intelligent tissue dispenser system. *International Journal of Recent Technology and Engineering*, 8(3), 2613. <https://doi.org/10.35940/ijrte.c4926.098319>
- Márquez-Vera, M. A., Martínez-Quezada, M., Calderón-Suárez, R., Rodríguez, A. G., & Ortega-Mendoza, R. M. (2023). Microcontrollers programming for control and automation in undergraduate biotechnology engineering education. *Digital Chemical Engineering*, 9, 100122. <https://doi.org/10.1016/j.dche.2023.100122>
- Mazalan, N., Zaman Huri, W. W., & Musa, M. J. (2024). Design and implementation of an eco-friendly tissue dispenser using Arduino, ultrasonic sensor, and motor. *Politeknik & Kolej Komuniti Journal of Social Science and Humanities*, 9(2), 26–33.
- Mian, S. H., Salah, B., Ameen, W., Moiduddin, K., & Alkhalefah, H. (2020). Adapting universities for sustainability education in Industry 4.0: Channel of challenges and opportunities. *Sustainability*, 12(15), 6100. <https://doi.org/10.3390/su12156100>
- Nurbekova, Z., Гриншкун, В., Aimicheva, G., Nurbekov, B., & Tuenbaeva, K. (2020). Project-based learning approach for teaching mobile application development using visualization technology. *International Journal of Emerging Technologies in Learning*, 15(8), 130. <https://doi.org/10.3991/ijet.v15i08.12335>
- Putra, N. A., Ahmadi, H. A., Putra, K. L. E. S., & Gunawan, A. A. S. (2021). IoT-project smart trash can with Blynk platform integration. *Engineering Mathematics and Computer Science (EMACS) Journal*, 3(3), 121. <https://doi.org/10.21512/emacsjournal.v3i3.7499>
- Royce, W. W. (1987). Managing the development of large software systems: Concepts and techniques. In *Ideas That Created the Future* (p. 328). <https://api.semanticscholar.org/CorpusID:110643636>
- Vicente, F. R., Llinares, A. Z., & Montés, N. (2020). Sustainable city: A STEAM project using robotics to bring the city of the future to primary

- education students. *Sustainability*, 12(22), 9696.
<https://doi.org/10.3390/su12229696>
- Vințe, C., Smeureanu, I., Dârdală, M., & Reveiu, A. (2021). Sustainable development in education – Automating curriculum assessment. *Technological and Economic Development of Economy*, 27(5), 1159–1176. <https://doi.org/10.3846/tede.2021.15018>
- Wanyama, J., Soddo, P., Nakawuka, P., Tumutegyereize, P., Bwambale, E., Oluk, I., Mutumba, W., & Komakech, A. J. (2023). Development of a solar powered smart irrigation control system kit. *Smart Agricultural Technology*, 5, 100273. <https://doi.org/10.1016/j.atech.2023.100273>
- Zondo, S., Ogudo, K. A., & Umenne, P. (2020). Design of a smart home system using Bluetooth protocol. *Proceedings of the International Conference on Artificial Intelligence, Big Data, Computing and Data Communication Systems(icABCD)*.
<https://doi.org/10.1109/icabcd49160.2020.9183815>