

High Power Femtosecond Yb Mode-Locked Pulse Laser Generation Using Hybrid Nonlinear Polarisation Rotation and FePS₃ 2D Material

Mohamad Akmal Mohamad Lutfi^{1*}, Harith Ahmad^{1,2,3,4},
Muhammad Zharif Samion¹ and Muhammad Khairol Annuar Zaini¹

¹Photonics Research Centre,
Universiti Malaya,
50603 Kuala Lumpur, Malaysia.

²Physics Department, Faculty of Science,
Universiti Malaya,
50603 Kuala Lumpur, Malaysia.

³Universiti Kuala Lumpur British Malaysian Institute,
Batu 8, Jalan Sungai Pusu, 53100 Gombak, Selangor, Malaysia.

⁴Department of Physics, Faculty of Mathematics and Natural Sciences,
Universitas Negeri Malang,
Jalan Semarang 5, Malang, 65145, Indonesia.

*Corresponding Author's Email: akmalutfi26@um.edu.my

Article History: Received 29 May 2024; Revised 29 October 2024;
Accepted 8 November 2024

©2024 M.A.M. Lutfi et al. Published by Jabatan Pendidikan Politeknik dan Kolej Komuniti.
This is an open access article under the CC BY-NC-ND license (<https://creativecommons.org/licenses/by-nc-nd/4.0/>).

Abstract

Developing high-power ultrashort pulse lasers is important for numerous advanced applications in science and technology, such as laser cutting and micromachining. Previous work in this area has often been limited to achieving low-power outputs, hindering the broader application potential of these lasers. This work demonstrated both high power and ultrashort pulses in ytterbium (Yb) mode-locked lasers by the integration of hybrid nonlinear polarisation rotation (NPR) with iron phosphate trisulfide (FePS₃) two-dimensional (2D) material saturable absorber (SA). The primary objective of this research is to enhance the performance of mode-locked fibre lasers, achieving ultrashort pulse durations and higher output power. A novel ytterbium-doped fibre laser (YDFL) system was designed, merging the advanced NPR technique with FePS₃-SA. The experimental configuration yielded a laser emitting at a central wavelength of 1077 nm, featuring an impressive 3-dB bandwidth of 19.8 nm, and generating pulse durations as brief as 0.14 ps. Operating at a repetition rate of 22.6 MHz, the laser achieved an outstanding signal-to-noise ratio (SNR) exceeding 60 dB. Furthermore, the hybrid mode-locked fibre laser exhibited optical peak and average output powers of 245 kW and 0.67 W, respectively. The successful deployment of this cutting-edge hybrid mode-locking technique opens new opportunities for groundbreaking research and innovation in the field of fibre lasers. This work not only demonstrates a significant leap in laser technology but also sets a new benchmark for future explorations and applications in ultrafast optics and photonics.

Keywords: Femtosecond Lasers, High-Power Laser, Hybrid Mode-Locking, Nonlinear Polarisation Rotation, Ultrashort Pulses

1.0 Introduction

Femtosecond mode-locked fibre lasers are essential in scientific research and various industrial applications due to their ability to generate ultrafast pulses [1], [2], [3], [4]. Unlike active mode-locking methods utilising acoustic or electro-optic modulators [5], the passive mode-locking approach stands out in ultrafast fibre laser sources due to its convenience and exceptional performance [6], [7], [8]. NPR is one mode-locking technique that implements artificial SA in the context of passively mode-locked fibre lasers, primarily due to its cost-effectiveness and ease of operation. NPR mode-locking harnesses saturable absorption effects from specific nonlinear phase shifts caused by Kerr's effect. However, NPR systems face significant challenges, including sensitivity to environmental and temperature fluctuations, as well as low signal-to-noise ratios (SNR), which limit their effectiveness in demanding applications [9], [10]. The nonlinear evolution of the polarisation state, driven by phase shifts induced by cross-phase modulation (XPM) and self-phase modulation (SPM) during pulse propagation in optical fibres, demonstrates an intensity-dependent behaviour [11].

Utilising two-dimensional (2D) materials as saturable absorbers (SAs) represents a dynamic approach to achieving mode-locking within laser systems. Typically, the SA acts as a nonlinear filter, facilitating reduced noise jitter and narrower pulse widths. Recent literature has highlighted various 2D material-based SAs, demonstrating their effectiveness as passive pulse modulators [12], [13], [14]. However, it is crucial to acknowledge that these 2D SAs come with limitations. For instance, graphene-based SAs display relatively low absorption efficiency, measuring only 2.3% at 1550 nm. In such scenarios, researchers have explored the incorporation of dual mode-locking technologies, creating hybrid mode-locked configurations. These hybrid systems offer notable advantages, particularly in reducing pulse width, enhancing stability, enabling self-started, and amplifying pulse signal-to-noise ratio (SNR) [15], [16], [17], [18].

This research introduces a novel hybrid mode-locking approach that synergistically integrates the unique properties of the two-dimensional material FePS₃ deposited on a side-polished optical fibre with the NPR technique. This innovative hybrid mode-locking configuration has yielded great results, enabling the generation of a stable and consistent output pulse with exceptional characteristics. Notably, the hybrid mode-locked laser system demonstrates a central wavelength of 1077 nm, residing within the technologically significant near-infrared region of the electromagnetic spectrum. This wavelength range finds widespread applications in diverse fields, including telecommunications, remote sensing, and biomedical imaging, making our findings highly relevant and promising for future technological advancements [19].

One of the standout features of this hybrid mode-locking approach is the ultrashort pulse duration achieved. The output pulses exhibit a brief temporal duration of 0.14 ps under the regime of noise-like pulses. Such ultrashort

pulses are valuable in various applications, including ultrafast spectroscopy, nonlinear optics, and the study of ultrafast dynamics in materials and biological systems. Furthermore, the hybrid mode-locked laser system shows an impressive signal-to-noise ratio (SNR) exceeding 60 decibels (dB). This exceptional SNR indicates a robust and clean output signal with minimal noise contamination, ensuring high-fidelity data acquisition and reliable performance in demanding applications that require precise signal detection and analysis. The successful integration of the two-dimensional material FePS₃ with the NPR technique in our hybrid mode-locking setup opens up exciting avenues for exploration and optimization. The unique properties of FePS₃, combined with the well-established NPR method, have unlocked a powerful synergy that enables the generation of ultrashort pulses with remarkable stability, spectral purity, and temporal confinement.

2.0 Methodology

In this experimental setup, ring cavities were structured with a 2-meter-long ytterbium-doped double-clad fibre (Coherent LMA-YDF-10/130-M) as the gain medium. This ytterbium-doped fibre (YDF) holds specific characteristics, including a cutoff wavelength falling within the range of 950±50 nm, a core numerical aperture (NA) of 0.120, a first cladding NA of 0.46, and a cladding absorption coefficient of roughly 0.55±0.10 dB/m at 915 nm. To address potential overheating concerns during high-power operations, we implemented a protective polymer coating and a graphene layer at the splice points of the YDF. Figure 1 shows the configuration of the NPR mechanism and CuO-ZnO mode-locked laser. For the YDF's pumping process, two 976 multimode laser diodes (LDs) were connected to the pump combiner, enabling the incorporation of output from the two distinct pump laser diodes before introducing it into the LMA-YDF. These laser diodes provided a combined maximum output power of 16W.

The signal extracted from the cavity underwent analysis utilizing specialized equipment including a Thorlabs S148C optical power meter (OPM), a Rohde & Schwarz RTM3004 oscilloscope (OSC), a Rohde & Schwarz FPC1000 1-GHz radio frequency (RF) spectrum analyser (RFSA) connected to a 10-GHz InGaAs photodetector, an A.P.E PulseLink autocorrelator, and an Anritsu MS9740A optical spectrum analyser (OSA) with a 0.05 nm resolution. For determining the total net cavity dispersion, the calculation involved net dispersion = $L_{YDF}GVD_{YDF} + L_{HI1060s}GVD_{HI1060s}$, where L_{YDF} and $L_{HI1060s}$ denote the lengths of the YDF and HI1060 fibres, respectively. In the FePS₃ hybrid mode-locked (hybrid-ML) configuration, a real saturable absorber (SA) was introduced into the cavity alongside the PD-ISO, with a coupling ratio of 70:30 where 70% of the light goes back to the cavity while the remaining 30% as the output power. This arrangement aimed to retain 70% of the light within the cavity, enabling most of the light to pass through the SA for generating ultrashort pulses. The entire cavity spanned 7 meters, with 2 meters designated for the YDF gain medium, 6 meters came from the pigtail lengths of the HI1060 components, and 1 meter of FePS₃ SA. The calculated total net cavity dispersion was determined to be 0.14 ps².

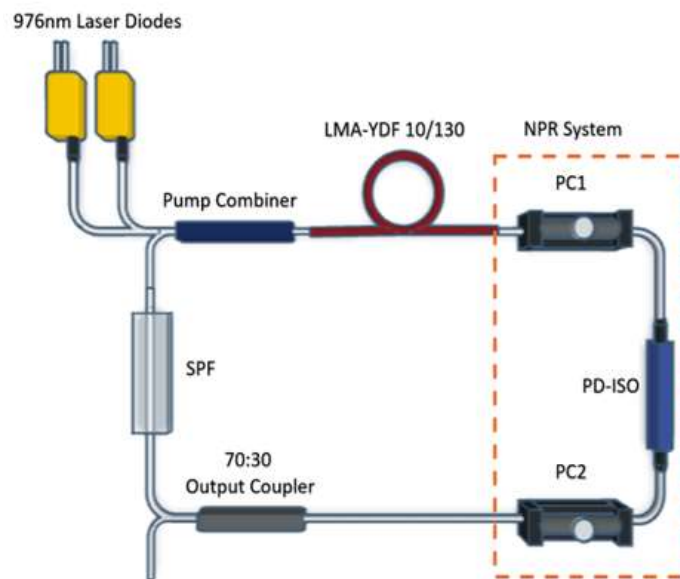

Figure 1: Configuration of the NPR mechanism and CuO-ZnO mode-locked laser. LMA-YDF: Large mode area Ytterbium-doped fibre PC: Polarisation Controller PD-ISO: Polarisation-dependent isolator SPF: Side-polished fibre

3.0 Results and Discussion

The introduction of a real SA into the cavity, combined with nonlinear polarisation rotation, has yielded distinct characteristics in mode-locking, marked by substantial improvements in stability, pulse duration, spectrum shaping, and signal-to-noise ratio (SNR). The characteristics of the hybrid mode-locked pulses were measured at a pump power of 12.2W and are presented in Figure 2. As shown in Figure 2(a), the output spectrum exhibits a Gaussian shape with a central wavelength of 1077 nm and a 3-dB bandwidth of 19.8 nm. Despite the net cavity dispersion being 0.14 ps², a broad and nearly Gaussian-like spectrum was obtained, indicative of noise-like pulses. The Gaussian-like spectrum is attributed to the irregular train of femtosecond sub-pulses. The temporal profile of the hybrid mode-locked pulses, measured using an autocorrelator, is depicted in Figure 2(b). The pulse duration is estimated at 0.14 ps, assuming a Gaussian pulse shape.

This ultra-short pulse duration is a significant achievement, enabled by the hybrid mode-locking mechanism. The SNR of the fundamental repetition frequency, measured using an electrical spectrum analyser, exceeds 60 dB, as shown in Figure 2(c). This high SNR value indicates excellent stability and pulse quality, which is crucial for various applications. The hybrid mode-locked YDF laser, leveraging both a real SA and NPR, has demonstrated remarkable performance characteristics, including a Gaussian-like spectrum, ultra-short pulse duration of 0.14 ps, and high SNR exceeding 60 dB. These results highlight the potential of this configuration for generating high-quality, stable pulses in the 1 μ m wavelength region, with applications in telecommunications, material processing, and medical diagnostics.

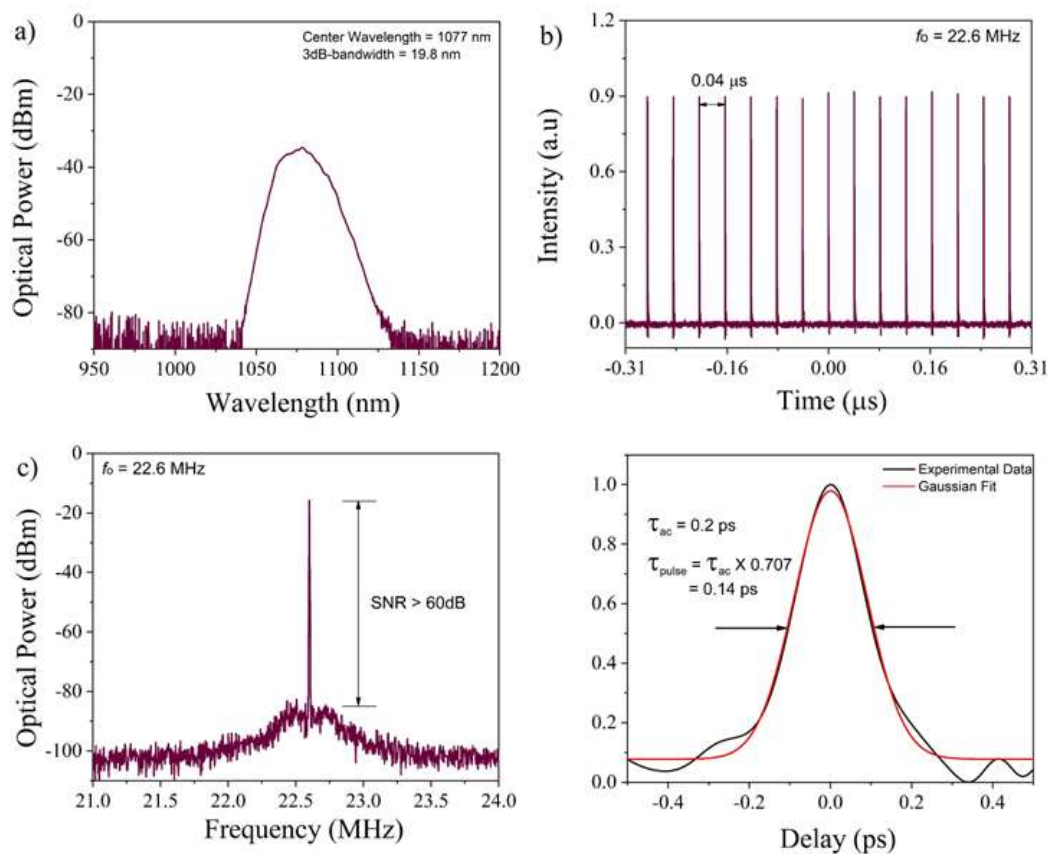

Figure 2: Characterisation of the Hybrid-ML pulses: (a) the optical spectrum, (b) the oscilloscope pulse train, (c) the radio frequency spectrum trace, and (d) the autocorrelation trace

Figure 2(b) illustrates the pulse train, showing an equally spaced pulsed with a spacing of 0.04 μ s with pulse train fluctuations of less than 3%. This corresponds to the frequency of 22.6 MHz, which is further verified by the radio frequency analysis presented in Figure 2(c). A relatively high SNR value of more than 60 dB was obtained. In the case of the generated ultrashort pulse width of 0.14 ps, which is due to the generation of noise-like pulses (NLPs). This typically happens when two distinct mode-locking mechanisms are integrated, the real SA and NPR. NLPs originate from the soliton collapse effect coupled with positive cavity feedback, where cavity losses decrease with the increasing peak power of the pulses. This phenomenon is commonly observed in pulsed lasers featuring a saturable absorber. As the pump power intensifies, there is a point of peak power clamping and subsequent pulse break-up. The newly generated multiple pulses undergo amplification and subsequent break-up, initiating a series of sequential processes that create the NLPs. Figure 3 plots the output power and peak optical power across varying pump levels, showing the highest recorded output power reaches 0.67W, with an optical peak power of 245kW.

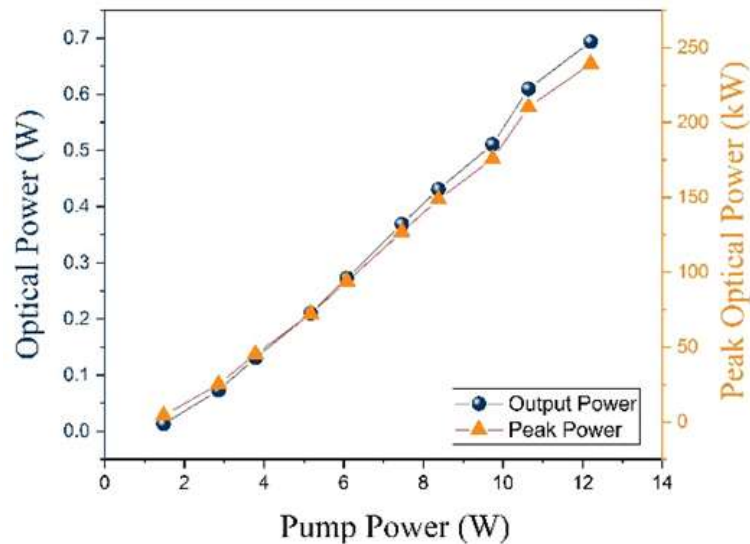

Figure 3: Double-Y graph comprising the average optical power (W) and peak optical power (kW)

4.0 Conclusion

The study presents a significant advancement in laser technology through the development of an all-normal-dispersion hybrid mode-locked YDF laser, which utilises a FePS₃ SA in conjunction with nonlinear polarisation rotation for effective mode-locking. The laser cavity is designed with a double-clad YDF, enhancing pump light absorption and minimising losses, which is crucial for achieving high performance. Notably, the laser demonstrates a maximum average output power of 0.67 W and generates ultra-short pulses with a duration of just 0.14 ps at a maximum pump power of 12.2 W. Additionally, it achieves a signal-to-noise ratio exceeding 60 dB, indicating excellent stability and pulse quality. The hybrid mode-locking mechanism effectively combines the advantages of both the saturable absorber and NPR, leading to improved pulse formation and enhanced stability under varying operational conditions. This innovative configuration not only showcases the potential for generating high-power, ultra-short pulses but also opens up exciting possibilities for applications in telecommunications, material processing, and medical fields, where precision and reliability are essential. Overall, the findings underscore the promise of the hybrid mode-locked YDF laser as a powerful tool for advancing laser technology and its diverse applications in the field of science and industry.

Acknowledgement

The authors would like to thank the Ministry of Higher Education Malaysia, and the University of Malaya for their support in facilitating this work.

Author Contributions

M. A. M. Lutfi: Methodology, Validation, Formal Analysis, Investigation, Writing – Original Draft, Writing – Review & Editing, Visualisation; **H. Ahmad:** Conceptual, Resources, Supervision, Funding Acquisition; **M. Z. Samion:**

Methodology, Resources, Supervision; **M. K. A. Zaini**: Methodology, Investigation, Supervision, Project Administration.

Conflicts of Interest

The manuscript has not been published elsewhere and is not under consideration by other journals. All authors have approved the review, agree with its submission, and declare no conflict of interest in the manuscript.

References

- [1] H. Ahmad, M. A. M. Lutfi, M. Z. Samion, M. K. A. Zaini, and N. Yusoff, "98 fs high energy stable hybrid mode-locked nonlinear polarization rotation with CuO-doped ZnO saturable absorber," *IEEE Journal of Quantum Electronics*, vol. 60, no. 4, pp. 1–11, 2024.
- [2] S. Kobtsev and A. Komarov, "Noise-like pulses: Stabilization, production, and application," *Journal of the Optical Society of America B*, vol. 41, no. 5, pp. 1116–1127, 2024.
- [3] D. T. Reid, "Ultrafast lasers: Technology and applications," *Journal of Microscopy*, vol. 211, no. 1, 2003.
- [4] W. Shi, Q. Fang, X. Zhu, R. A. Norwood, and N. Peyghambarian, "Fiber lasers and their applications [Invited]," *Applied Optics*, vol. 53, no. 28, 2014.
- [5] Y. Zhou et al., "Actively mode-locked all-fiber laser with cylindrical vector beam output," *Optics Letters*, vol. 41, no. 3, 2016.
- [6] H. Ahmad, M. A. M. Lutfi, M. Z. Samion, and M. K. A. Zaini, "108 fs high-power mode-locked double-clad ytterbium-doped fiber laser using FePS₃ saturable absorber," *Optical and Quantum Electronics*, vol. 56, no. 5, 2024.
- [7] X. Bao et al., "Ytterbium-doped fiber laser passively mode-locked by evanescent field interaction with CH₃NH₃SnI₃ perovskite saturable absorber," *Journal of Physics D: Applied Physics*, vol. 51, no. 37, 2018.
- [8] H. H. Wu, P. H. Huang, Y. H. Teng, A. Zaytsev, O. Wada, and C. L. Pan, "Automatic generation of noise-like or mode-locked pulses in an ytterbium-doped fiber laser by using two-photon-induced current for feedback," *IEEE Photonics Journal*, vol. 10, no. 6, 2018.
- [9] H. Ahmad, M. H. M. Ahmed, N. Yusoff, R. Ramli, and M. Z. Samion, "All-fiber normal dispersion mode-locked ytterbium-doped double-clad fiber laser using fiber taper with WS₂-ZnO saturable absorber," *Optics and Laser Technology*, vol. 130, p. 106350, Oct. 2020.
- [10] M. F. M. Rusdi et al., "Molybdenum disulphide tape saturable absorber for mode-locked double-clad ytterbium-doped all-fiber laser generation," *Chinese Physics Letters*, vol. 33, no. 11, 2016.
- [11] J. Lang, C. Lv, B. Lu, and J. Bai, "Mechanism of noise-like pulse in all-normal dispersion all-fiber laser based on nonlinear polarization rotation," *Optics Express*, vol. 32, no. 2, 2024.
- [12] J. Peng, R. Zhu, T. Shen, Y. Liu, Y. Ma, and F. Gu, "2D saturable

- absorbers for potential pulse generation in the visible-wavelength band,” *Photonics*, vol. 10, no. 5, 2023.
- [13] G. Wang, A. A. Baker-Murray, and W. J. Blau, “Saturable absorption in 2D nanomaterials and related photonic devices,” *Laser and Photonics Reviews*, vol. 13, no. 7, 2019.
- [14] R. I. Woodward and E. J. R. Kelleher, “2D saturable absorbers for fibre lasers,” *Applied Sciences (Switzerland)*, vol. 5, no. 4, 2015.
- [15] X. Li, D. N. Wang, K. Hua, Q. Chen, Y. Ge, and Q. K. Xia, “Saturable absorber based on graphene for a hybrid passive mode-locked erbium-doped fiber laser,” *Optical Fiber Technology*, vol. 70, 2022.
- [16] C. Ma et al., “MXene saturable absorber enabled hybrid mode-locking technology: A new routine of advancing femtosecond fiber lasers performance,” *Nanophotonics*, vol. 9, no. 8, 2020.
- [17] J. Mohanraj and M. Valliammai, “Spectrum analysis of ytterbium-doped hybrid mode-locked fiber laser,” in *2019 Workshop on Recent Advances in Photonics (WRAP 2019)*, 2019.
- [18] G. Soboń, “Noise-like pulses in mode-locked fiber lasers,” in *Springer Series in Optical Sciences*, vol. 238, Cham: Springer International Publishing, 2022, pp. 319–337.
- [19] H. Ahmad, M. A. M. Lutfi, B. Ortaç, M. K. A. Zaini, and M. Z. Samion, “Evolution of noise-like pulses to watt-level all-fiber supercontinuum in compact all-normal dispersion fiber laser using nonlinear polarization rotation,” *Optical Fiber Technology*, vol. 87, p. 103861, Oct. 2024.